

PRORIL

50Hz

GOVOX-G Series, these vortex pumps feature a less impeller wear and longer pump life by a vortex flow that allows fibrous materials and solid matters to be pumped out without obstruction.

Sewage Pump

GOVOX-G 455/475

Vortex Pump



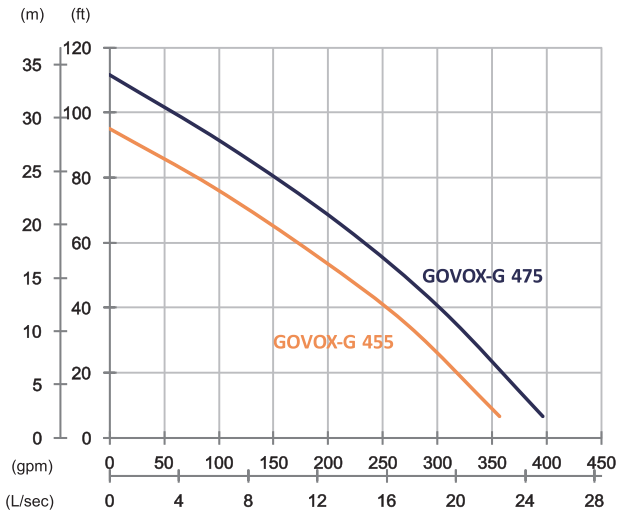

	GOVOX-G 455	GOVOX-G 475
OUTPUT	5.5 kW (7.5 HP)	7.5 kW (10 HP)
OUTLET	4" (100 mm)	4" (100 mm)
SOLID PASSAGE	52 mm	52 mm
Weight	73 kg	75 kg
HEAD	Rated: 17 m Max: 29 m	Rated: 20 m Max: 34 m
FLOW	Rated: 12 L/s Max: 22.5 L/s	Rated: 13.3 L/s Max: 25 L/s

Pump Type	Electric Submersible Pumps	
Motor	Phase	3-Phase
	Type	Induction Motor
	Poles	2 Pole (2850 rpm)
	Insulation	Class F
	Protector	Circle Thermal Protector
	Starter	D.O.L.
Lubricant	Food Grade (ISO VG32)	
Specs.	Impeller Type	Vortex
	Shaft Seal	Double Mechanical Seal
		Silicon Carbide VS Ceramic/Carbon
	Bearings	C3 Shielded ball bearings
Cable	H07RN-F	
	10 m or longer upon request	
Materials	Pump Casing	Gray Iron
	Impeller	Gray Iron
	Motor Frame	Gray Iron
	Motor Shaft	Stainless Steel
Max. Liquid Temperature	40°C (104°F)	
Max. Submersion Depth	20 m (66 ft)	
pH Range	pH 5 - pH 8	
Guide Rail	GRF-04	

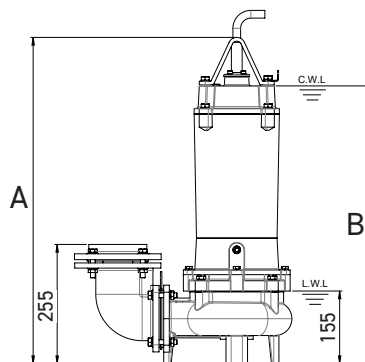
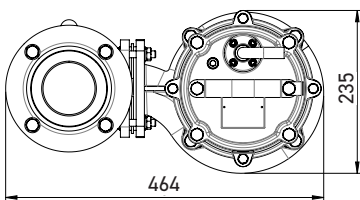

	A	B
GOVOX-G 455	697	593
GOVOX-G 475	719	615

unit : mm

C.W.L : Continuous running water level
L.W.L : Lowest running water level